

OCEANWELL

海益（厦门）建材工业有限公司

料号	236J760-E71-01C	版本	1.0
材质	100克双胶单黑印刷	尺寸	175X260mm
日期	2023.02.21	页数	16
表单编号		版本	1.0

USER MANUAL



Thank you for choosing Better Bathrooms.
Please read this manual before installing your product
and keep for future reference.

better 
bathrooms

Concealed Cistern BeBa_25879

Push Button BeBa_25873, BeBa_25875 & BeBa_26131

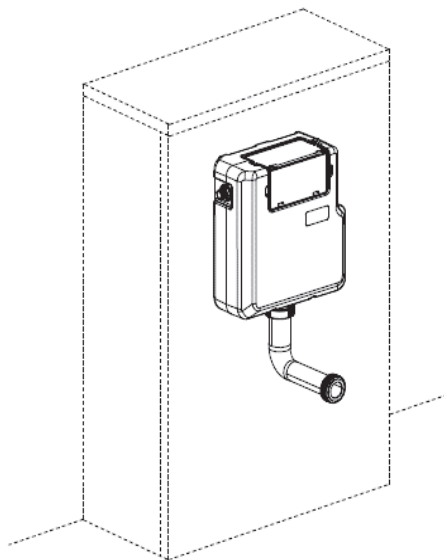

Please note: Image is for illustrative purposes only and may differ slightly to the actual product

- **Multi-person assembly**
- **Tools required**
- **We always recommend using professional tradespeople to install your product**

V1 6.7.20

Congratulations on your purchase

And welcome to our growing gang of savvy shoppers

We're on a mission to bring you extraordinary bathroom products, for less. From modern to traditional style ceramics, plus the gorgeous fixtures, fittings and furniture to match. So, you can fall in love with your space every single day.

As one of the UK's largest independent bathroom stores, we've received countless awards; including the National Business Awards UK, the Digital Entrepreneur Awards and being placed on The Sunday Times Fast Track 100.

We hope your new product goes above and beyond your expectations. However, should any problems occur, please:

- log in to your account and contact our customer services team via your self-serve portal – betterbathrooms.com/CustomerAccount/Login
- contact us via betterbathrooms.com/content/contact-us

Important information

- Please read these instructions thoroughly and retain for future reference.
- Manufactured to BS EN14055 WC and urinal cisterns.
- All installation work must be carried out to comply with the Water Bylaw Regulations.
- The installation should be designed to allow access for maintenance.

Contents

• Dimensions	4
• Data	4
• Parts	5-6
• Tools required	6
• Installation	
○ Fixing the Wall Bracket	7
○ Fixing the Cistern Tank	8
○ Fitting the Flush Pipe	8-9
○ Water Connection	9
○ Connecting Pneumatic Tubes	10
○ Connecting the Flush Button	11
○ Fixing the Toilet	12
• Troubleshooting	13
• Maintenance	14-16
• Cleaning	16

Dimensions

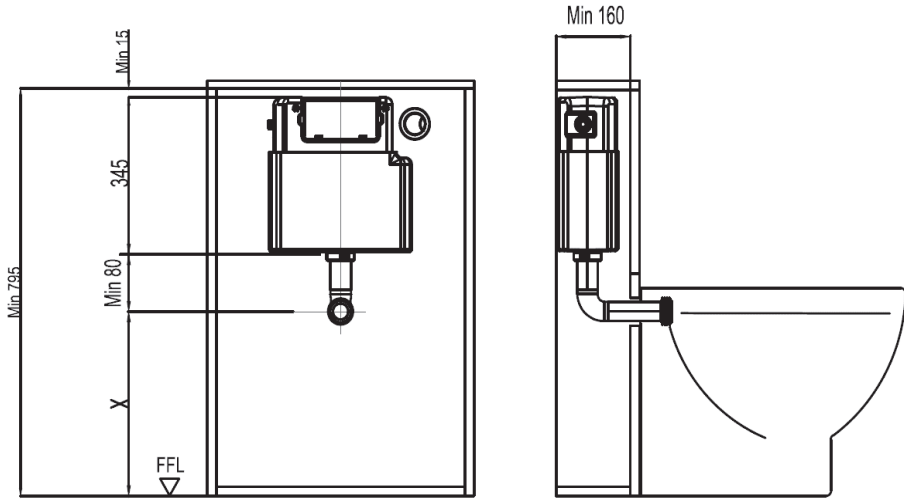

Data

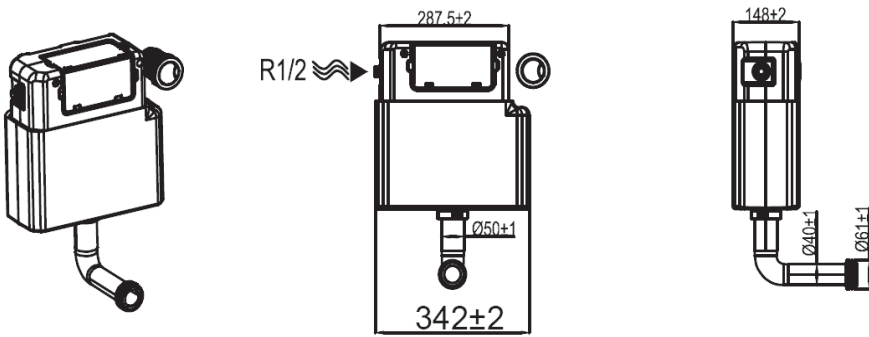

Left hand inlet

1/2" male end inlet connection

3 & 6 litre dual flush

Parts

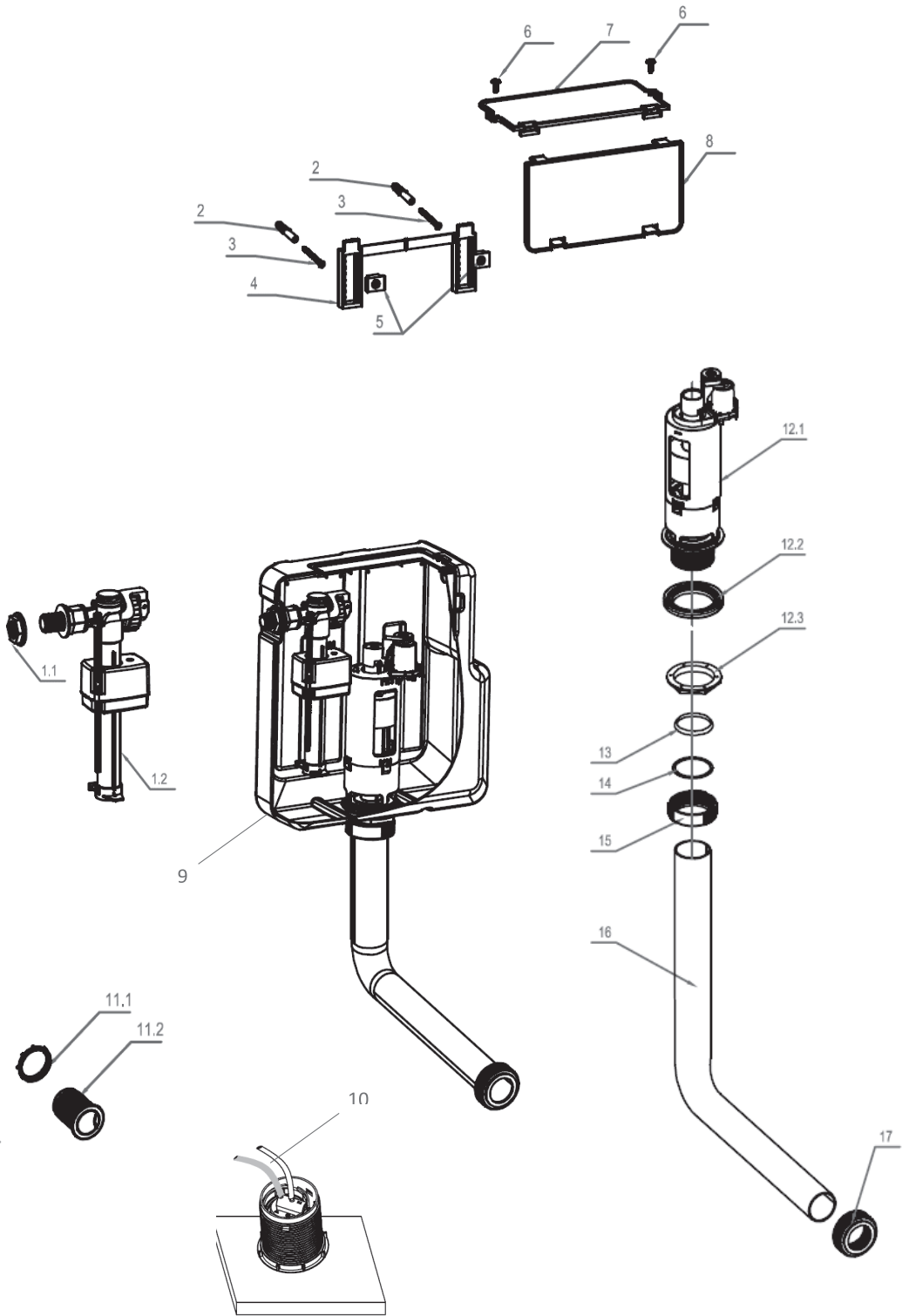

- 1.1. Inlet valve nut
- 1.2. Inlet valve
2. Wall plug
3. Screw
4. Wall bracket
5. Wall bracket inserts
6. Cistern lid screws
7. Cistern lid
8. Cistern face
9. Tank
10. Tubes
- 11.1. Push button nut
- 11.2. Push button
- 12.1. Syphon
- 12.2. Syphon/Cistern washer
- 12.3. Syphon nut
13. Flush pipe seal
14. Plastic washer
15. Syphon nut
16. Flush pipe
17. Flush pipe bung

Tools required

- Screwdriver (Cross Head)
- Spanner
- Pencil
- Drill
- Spirit Level
- 8mm Drill Bit
- File
- Hacksaw

Installation

Please note: Whenever possible and when safe to do so, it is recommended to carry out leak tests during the installation process

Fixing the Wall Bracket

Depending on your WC unit the fixing bracket may be fitted to either the wall behind the unit or to the back plinth of your WC unit.

Please note: The desired location should be checked before drilling, that no pipes or wires can be damaged

1. Place the wall bracket in its desired fixing position, central within the unit width.
2. Mark the drill holes, ensuring that the bracket is level.
3. Drill the holes using an 8mm drill bit (not supplied).
4. If fixing to brick, use the wall plugs provided and for any other material, use a suitable plug type, if required.
5. Fit the screws to secure the bracket to the wall/unit.

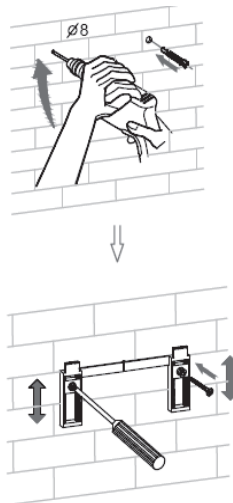
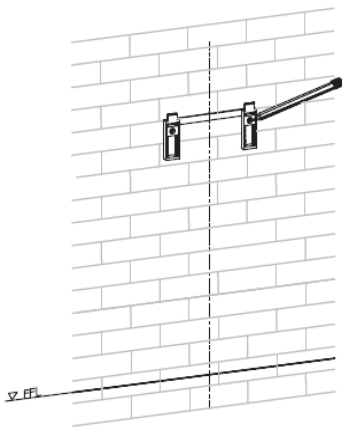

Fixing the Cistern Tank

1. Hook the cistern tank onto the bracket via the slots located on the rear of the tank.
2. Slide the tank so that it is central with the unit space.

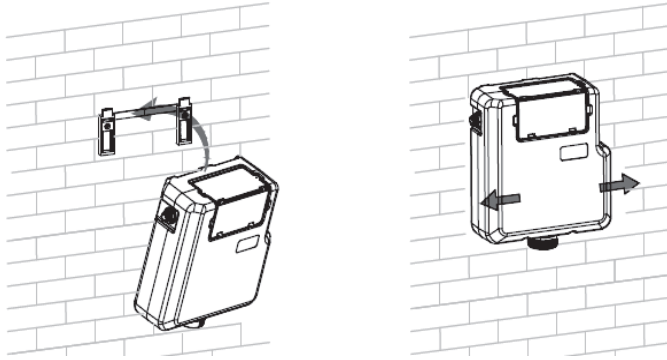

Fitting the Flush Pipe

1. As per the diagram below, carry out the measuring process to establish the required length of the vertical (Larger diameter) section of the pipe to allow alignment with the flush hole on the toilet pan. Once cut, file off any rough edges.
2. Place the larger diameter end of the 90° flush pipe into the hole on the underside of the cistern tank then push the toilet pan toward the tank and insert the pipe into the rear of the toilet to establish the length of the horizontal pipe required and to allow the toilet pan to push back to the unit. Once this has been determined cut as required and file off any rough edges.

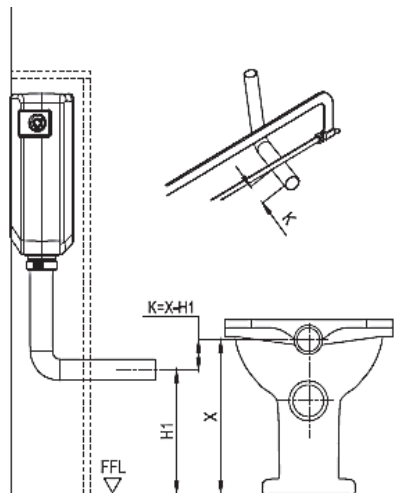

3. To fit the 90° flush pipe to the cistern tank, fit the nut over the pipe first, followed by the plastic washer then finally fit the angled rubber seal, with the angled section in the upward position.
4. Once these have been fitted to the pipe, push the pipe into the hole on the tank then tighten the nut until secure taking care not to overtighten.

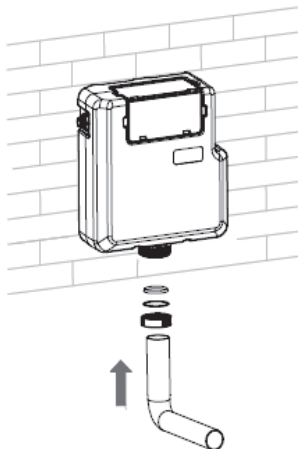

Water Connection

1. Make the connection between the water supply and the cistern tank, and ensure to include a stop valve (not included).
2. The water supply pipe not included should have a 1/2" female flat faced connector to connect to the thread on the cistern inlet valve.

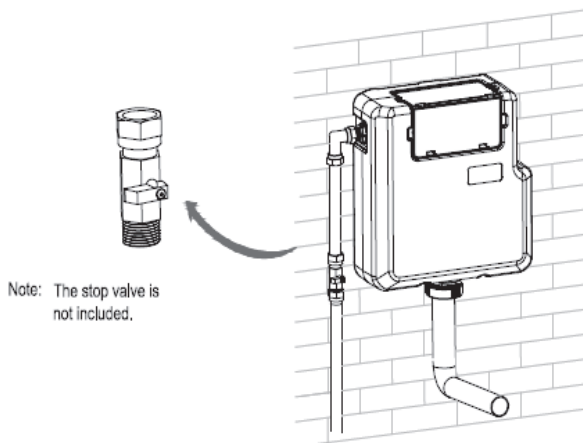

Connecting Pneumatic Tubes

1. To gain access to the internals of the cistern and the pneumatic tubes remove the face and lid.
2. To remove the face push upwards on the two clips at the bottom of the face and pull forwards.
3. To remove the lid, use a cross head screwdriver to remove the retaining screws.
4. Depending on your desired installation and unit, you are able to swap the lid and face to give access either from the front or from the top.
5. Once you have access, feed the pneumatic tubes through the holes in the side of the cistern as shown.

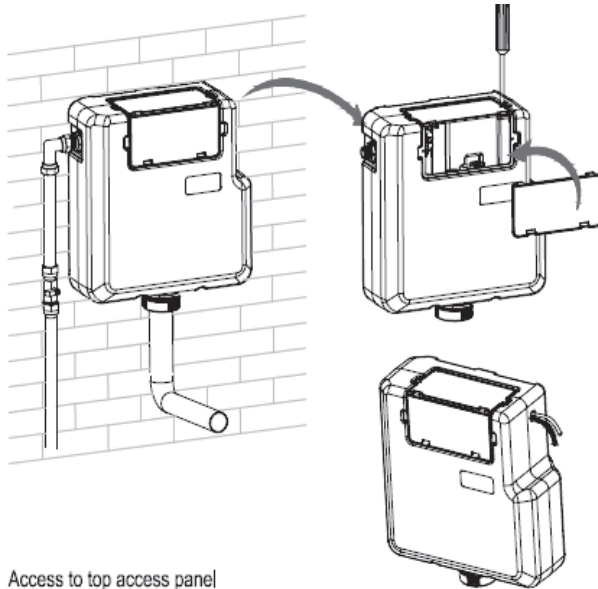

Access to top access panel

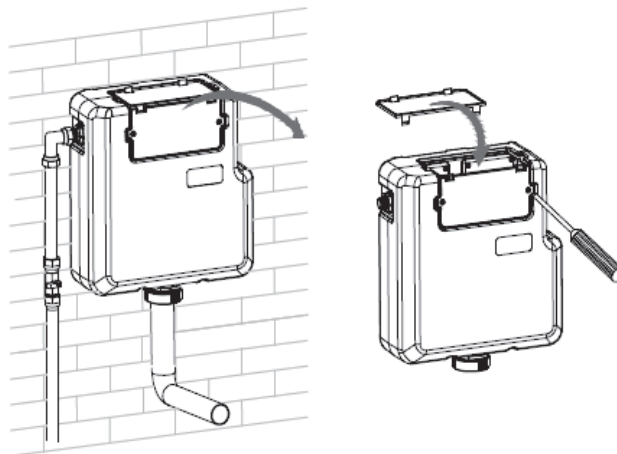

Connecting the Flush Button

1. To select the position of your push button will be dependent on the unit width as you will need to have the tank centrally located and have sufficient space to allow unobstructed installation of the push button.
2. Once this location has been decided, use a hole cutter to make a 63mm diameter hole in the unit, take great care when making this cut, not to oversize the hole.
3. Place the push button through the hole and connect the nut and tighten until secure, do not overtighten as this could crack the nut.
4. Connect the pneumatic tubes to the inlets on the push button.
5. The blue tube must be connected to the inlet indicated with a blue sticker.
6. Ensure the tubes are pushed on securely.

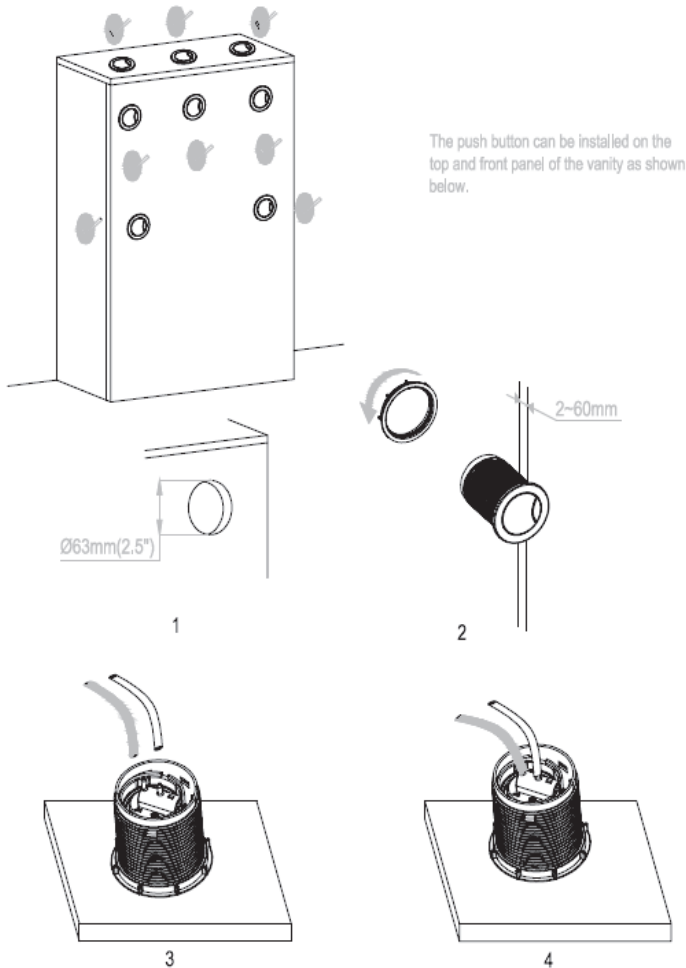

Fixing the Toilet

1. Push the flush bung onto the end of the flush pipe.
2. Apply a small amount of lubricant (washing up liquid) to the bung. This will assist the insertion of this into the flush hole on the toilet pan.
3. Push the toilet pan back to flush pipe and guide this into the flush hole. until the toilet pan sits flat against the WC unit.

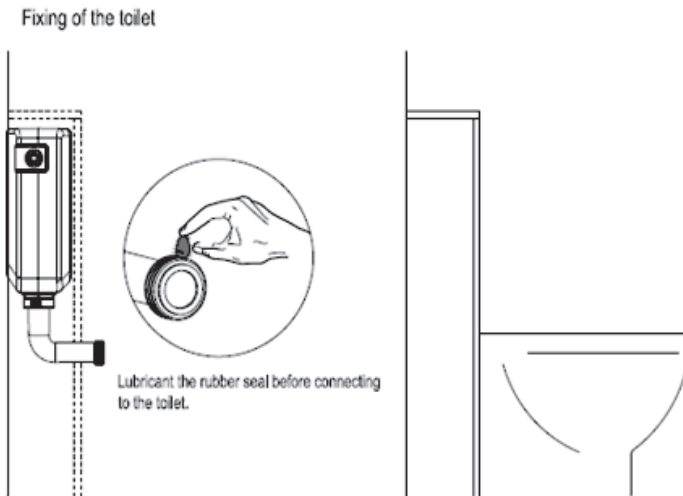

Please note: Once installation is completed a full commissioning of the product should be carried out to check the installation is safe and stable, check for leaks and check function

Troubleshooting

For all troubleshooting solutions, please refer to the Maintenance section.

Water running into the pan continually after flushing

1. Establish if the water level in the cistern is reaching the overflow on the syphon, if it doesn't, replace the upper section of the syphon.

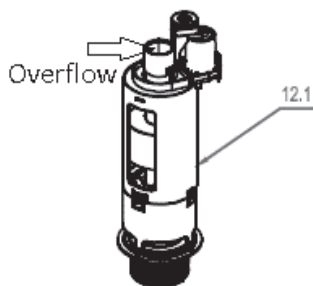

Insufficient or too much water entering the cistern tank

1. Adjust the inlet valve using the adjustment screw.

Filling of the cistern slows

1. If the water flows into the cistern slows the filter on the inlet valve could be blocked and may require cleaning.
2. Remove and run under warm water and clean using a small brush to remove any blockage, if this does not resolve the issue, check the water supply to the cistern.
3. If this is running freely, replace the inlet valve.

No flush operation when push button is pressed

1. Remove the push button tubes and blow down the tubes to determine if this activates the flush, if it does replace the push button.
2. If it does not replace the top section of the syphon.

Tank fills correctly but insufficient water leaving the tank

1. Adjust the syphon volume.

Maintenance

For all maintenance measures below, you will need to gain access to the cistern tank by removing panels/tops on your WC unit, (this access will differ depending on your WC unit), and for the water supply to be turned off.

Once you have gained access, remove the screws in the tank face/lid and this will release the second section of the face/lid by unclipping from the tank.

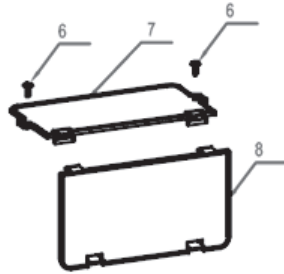

Inlet valve adjustment

Twist the adjustment screw as shown in the direction required.

Maintenance of the cistern fittings:

Maintenance of fill valve

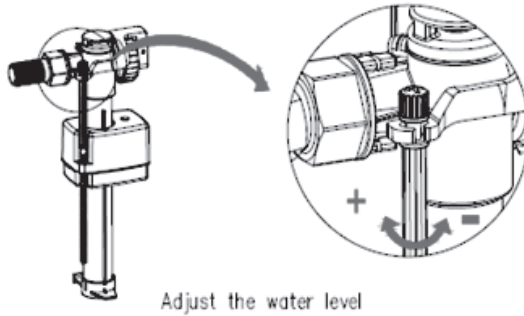

Adjust the water level

Inlet valve filter cleaning

- Unscrew the filter section from the inlet valve.
- Place the filter under warm running water and brush to remove any blockage.
- Then replace and tighten back into position.

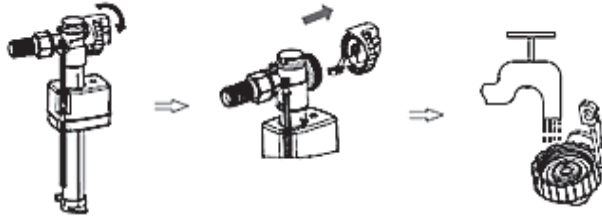

Syphon removal and adjustment

- The syphon is made of two parts, the bottom section which is secured to the cistern tank and the upper section which can twist and pull away from the bottom section.
- During this maintenance the bottom section can remain in position
- To adjust the volume of water leaving the tank, move the slider as shown.
- If you need to remove the syphon to check the washer or remove the washer for cleaning, follow the same process, but you may also need to remove the tubes, simply pull these from each of the syphon inlets.

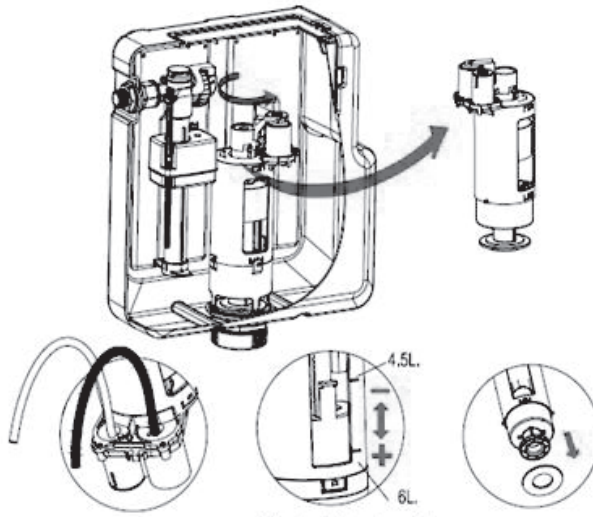

Push button operation failure

- Once you have gained access inside the cistern, simply pull the tubes from the pipe inlets.
- Hold them together and blow down the tubes, this should operate the flush of the syphon.
- If it does, unscrew the push button by removing the nut on the rear inside the unit and replace.

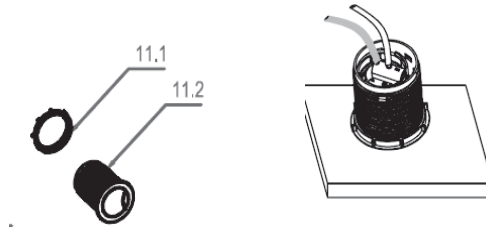

Cleaning

To maintain the surface of the push button surface, wipe with a clean damp cloth and wipe dry, do not use any abrasive cleaning agents or materials.

If any harsh chemicals come into contact with the surface of the product, rinse and wipe clean immediately.

For more information

- visit betterbathrooms.com
- email customerservices@buyitdirect.co.uk
- call 0330 390 3062
- write to Trident Business Park, Neptune Way, Huddersfield, HD2 1UA

**better
bathrooms**

Part of the BuyItDirect Group